

◆ ◆ ◆ ◆ ◆
◆ ◆ ◆ ◆ ◆

Instruction manual

◆ ◆ ◆ ◆ ◆
◆ ◆ ◆ ◆ ◆

C.E.M. Controlled Evaporator and Mixer W-300B

Doc. no.: 9.17.082B Date: 14-03-2017

◆ ◆ ◆ ◆ ◆
◆ ◆ ◆ ◆ ◆
◆ ◆ ◆ ◆ ◆
◆ ◆ ◆ ◆ ◆

ATTENTION

**Please read this instruction manual carefully before installing and operating the instrument.
Not following the guidelines could result in personal injury and/or damage to the equipment.**

◆ ◆ ◆ ◆ ◆
◆ ◆ ◆ ◆ ◆

Even though care has been taken in the preparation and publication of the contents of this manual, we do not assume legal or other liability for any inaccuracy, mistake, mis-statement or any other error of whatsoever nature contained herein. The material in this manual is for information purposes only, and is subject to change without notice.

Warranty

Bronkhorst® products are warranted against defects in material and workmanship for a period of three years from the date of shipment, provided they are used in accordance with the ordering specifications and the instructions in this manual and that they are not subjected to abuse, physical damage or contamination. Products that do not operate properly during this period may be repaired or replaced at no charge. Repairs are normally warranted for one year or the balance of the original warrant, whichever is longer. See also paragraph 9 of the Conditions of sales.

The warranty includes all initial and latent defects, random failures, and undeterminable internal causes.

It excludes failures and damage caused by the customer, such as contamination, improper electrical hook-up, dropping etc.

Re-conditioning of products primarily returned for warranty service that is partly or wholly judged non-warranty may be charged for.

Bronkhorst HIGH-TECH B.V. prepays outgoing freight charges when any party of the service is performed under warranty, unless otherwise agreed upon beforehand. However, if the product has been returned collect to Bronkhorst HIGH-TECH B.V., these costs are added to the repair invoice. Import and/or export charges, foreign shipping methods/carriers are paid for by the customer.

Safety Precautions

The following safety precautions should be observed before using this product and any associated instrumentation. Although some instruments and accessories would normally be used with non-hazardous voltages, there are situations where hazardous conditions may be present.

This product is intended for use by qualified personnel who recognize shock hazards and are familiar with the safety precautions required to avoid possible injury. Read the operating information carefully before using the product.

Before operating an instrument, make sure the line cord is connected to a properly grounded power receptacle. Inspect the connecting cables, test leads, and jumpers for possible wear, cracks, or breaks before each use.

The instrument and accessories must be used in accordance with its specifications and operating instructions or the safety of the equipment may be impaired.

When fuses are used in a product, replace with same type and rating for continued protection against fire hazard.

Opening of the equipment is not allowed. There are no repairable parts inside. In case of a defect please return the equipment to Bronkhorst High-Tech.

The  symbol on an instrument indicates that the user should refer to the operating instructions located in the manual.

Surfaces near the  symbol may be hot.

To maintain protection from electric shock and fire, replacement components in mains circuits, must be purchased from Bronkhorst®. Standard fuses, with applicable national safety approvals, may be used if the rating and type are the same. Other components that are not safety related may be purchased from other suppliers as long as they are equivalent to the original component. (Note that selected parts should be purchased only through Bronkhorst® to maintain accuracy and functionality of the product.) If you are unsure about the applicability of a replacement component, call a Bronkhorst® office for information.

Short-Form Operation Instruction

- Before installing your CEM system it is important to check:
 - * flow rate
 - * fluids to be controlled/evaporated
 - * up- and downstream pressures
 - * output signals
 - * heater temperature

- Watch the red-coloured stickers and make sure the test pressures are in agreement with normal safety factors for your application.

- Check if the piping system is clean. Always install filters to assure particle free fluids.

- Install the CEM system and tighten the fittings according to the instructions of the supplier of the fittings.

- Check the system for leaks before applying fluid pressure.

- In systems with corrosive or reactive fluids, purging with an inert gas is absolute necessary before use. Complete purging after use with corrosive or reactive fluids is also required before exposing the system to air.

- Apply the controlled power to the heat exchanger and wait till the temperature is stabilised.

- Your CEM system is now ready for operation.

- Be sure that your liquid system is free of gas bubbles. If needed remove the de-aerate plug on top of the CEM control valve for de-aeration.

TABLE OF CONTENTS

1 Introduction

1.1	General	page 7
1.2	Principle of operation	page 7
1.3	CEM set-up	page 7

2 Installation

2.1	Receipt of equipment	page 8
2.2	Return shipment	page 8
2.3	Service	page 8
2.4	Mounting position	page 8
2.5	Liquid filling	page 8
2.6	In-line filter	page 9
2.7	Fluid connections	page 9
2.8	Electrical connections	page 9
2.8.1	General	page 9
2.8.2	Pin configuration	page 9
2.9	Electrical specifications	page 10
2.9.1	Functional diagram	page 10
2.9.2	Electrical specifications	page 10
2.10	Caution	page 10
2.11	Supply pressure	page 11
2.12	System purging	page 11
2.13	Seals	page 11

3 Operation

3.1	General	page 12
3.2	Power and warm-up	page 12
3.3	Start-up/close-down	page 12

4 Readout and control unit

4.1	Application with Bronkhorst® standard Readout and Control unit	page 14
4.1.1	General	page 14
4.1.2	Rear panel connector	page 14
4.1.3	Operation	page 14
4.2	Application with none Bronkhorst® standard Readout and Control unit	page 15
4.2.1	Recommended graphical diagram heater system	page 15

5 Cables

5.1	EMC and cables	page 16
-----	----------------------	---------

Appendices

1	Recommendations for handling the Bronkhorst® DLI (CEM) System
	A. Vacuum system
	B. Non Vacuum system
2	Enclosures

1 Introduction

1.1 General

The Bronkhorst® series CEM system is a unique system to realise Mass Flow Control of vapour & mixtures, containing up to 1200 g/h vapour. A complete system is a combination of a mixing valve, a heating device, a liquid meter with control function and a mass flow controller for the carrier gas. The liquid flow through the liquid meter is controlled by the mixing valve. A complete system also incorporates a readout/control unit, including power supply for operation of the CEM system devices.

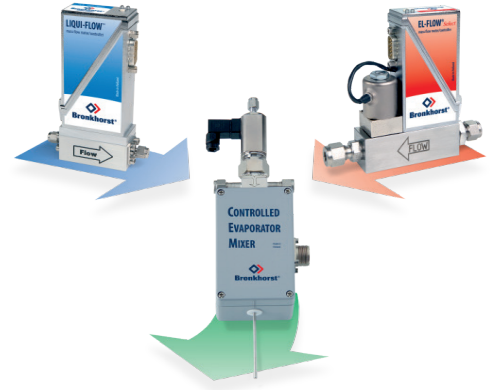

1.2 Principle of operation

The abbreviation "**CEM**" stands for:

"C" the control of a flow of gas mixture, gas, liquid or liquid/gas mixture

"E" the evaporation of a flow of liquid/gas mixture by means of a temperature controlled heating device

"M" the mixing of a gas and a liquid (vapour).

At room temperature the liquid, for instance water or TEOS, is drawn from a container with an inert gas blanket, or membrane, and measured by a liquid mass flow meter type μ -FLOW* or LIQUI-FLOW®*. The required flow rate is controlled to the setpoint value by a control valve that forms an integral part of the CEM system.

A carrier gas, controlled by a MFC* is used to stimulate the evaporation process as a mixing component, and furthermore to transport the vapour.

The process is highly repeatable and efficient.

Subsequent total evaporation of the liquid is achieved in the CEM.

* For operation of these devices consult the appropriate instruction manuals.

1.3 CEM set-up

The CEM system is built up around 3 different parts; a control valve, a mixing device and a heat exchanger in which heat is added to the mixture of fluids for evaporation and furthermore to prevent condensation. The temperature of the heat exchanger is controlled by a temperature controller which is part of the readout and control unit.

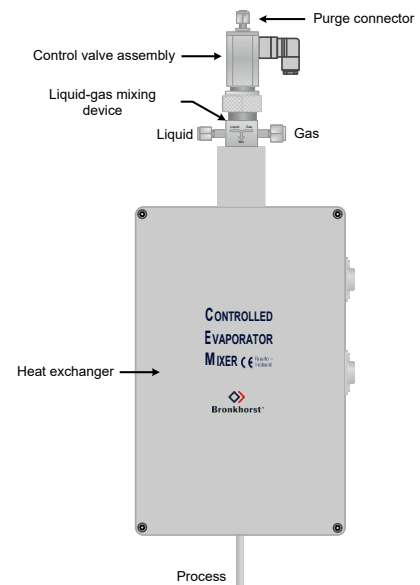

2 INSTALLATION

2.1 Receipt of equipment

Check the outside packing box for damage incurred during shipment. Should the packing box be damaged, then the local carrier must be notified at once regarding his liability, if so required. At the same time a report should be submitted to:

BRONKHORST HIGH-TECH B.V.
RUURLO HOLLAND

Remove the envelope containing the packing list; carefully remove the equipment from the packing box. Do not discard spare- or replacement parts with the packing material and inspect the contents for damaged or missing parts.

2.2 Return shipment

When returning material, always describe the problem and if possible the work to be done, in a covering letter.

It is absolutely required to notify the factory if toxic or dangerous gases have been metered with the instrument!

This to enable the factory to take sufficient precautionary measures to safe-guard the staff in their repair department. Take proper care of packing, if possible use the original packing box; seal instrument in plastic etc.

All instruments must be dispatched with a completely filled in 'declaration on contamination form'. (In the back of this manual)

Instruments without this declaration will not be accepted.

Note:

If the instruments have been used with toxic or dangerous gases the customer should pre-clean the instrument.

Important:

Clearly note, on top of the package, the customer clearance number of BRONKHORST HIGH-TECH B.V., namely:

NL801989978B01

2.3 Service

If this equipment is not properly serviced, serious personal injury and/or damage to the equipment could be the result. It is therefore important that trained and qualified service personnel perform servicing. Bronkhorst® has a trained staff of servicemen available.

2.4 Mounting position

Preferably the CEM system is mounted in a vertical position, with the control valve section pointing upwards and the vapour output pointing downwards.

Avoid installation in close proximity of mechanic vibration or strong heat sources.

2.5 Liquid filling

The purge connector can be used to remove the air from the liquid system. If available, use vacuum to de-aerate the valve and liquid flowmeter before filling with liquid.

2.6 In-line filter

Although fluids and piping should be absolutely free from dirt, it is recommended to install inline filters upstream of the flowmeter(s).

2.7 Fluid connections

The liquid meter should be installed according to its manual. The outlet of this meter should be connected to the liquid input port of the CEM valve. The controller section of the liquid flowmeter controls the CEM valve. Electrical connections should be made according to the customer system description.

The outlet of the gas flow controller must be connected to the gas input part of the CEM valve.

The vapour outlet of the CEM should be directly coupled to the process, this tube should be heated at a temperature higher than the heater in order to assure that the vapour will not condense in this line. Avoid “cold spots” in the outlet.

*** Note:** Always check your system for leaks, before applying fluid pressure. Especially if toxic, explosive or other dangerous fluids are used.

2.8 Electrical connections

2.8.1 General

Bronkhorst® recommends using their standard Readout and Control module and standard cables, which have been tested together with the system. These cables are always supplied with the CEM system.

When not using the standard Readout and Control unit please read chapter 4.

2.8.2 Pin configuration

The heat exchanger is equipped with two connectors:

connector (1) 6-pin male

Pinnumber	Description
A	Not connected
B	Not connected
C	PT100 (T-sensor)
D	PT100 (T-sensor)
E	Safety switch
F	Safety switch

connector (2) 5-pin male

Pinnumber	Description 110...120Vac supply	Description 220...240Vac supply
A	PE	PE
B	Heater (N)	Not connected
C	Heater (L)	Heater (N)
D	Heater (L)	Heater (L)
E	Heater (N)	Not connected

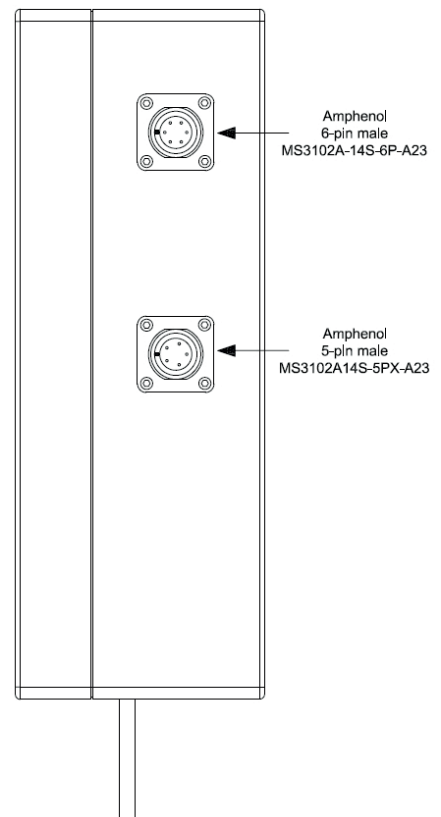

2.9 Electrical specifications

2.9.1 Functional diagram

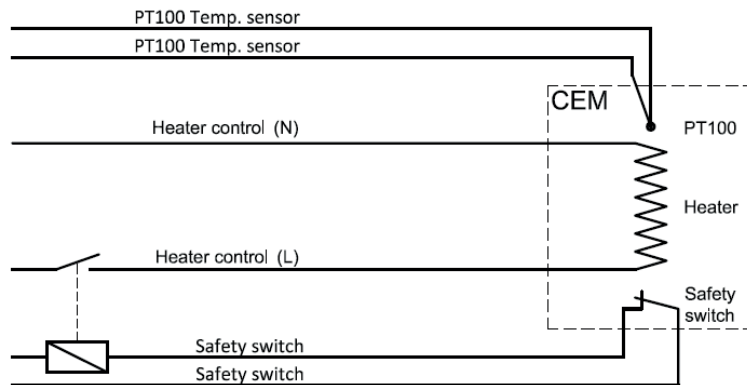

2.9.2 Electrical specifications

Heater

The heater consists of two heater elements with a resistance of approx. $19,25 \pm 0,5$ Ohm each.

For 110...120Vac-power supply: two heater elements switched parallel.

For 220...240Vac-power supply: two heater elements switched serial.

Temperature sensor

Heraeus Sensor PT 100 sensor M-K 2515 1PT100

Safety switch:

Pepi Miniature Thermostat Model C, CH version

Switch temperature: 200 °C

Contact rating: 24Vdc max / 3A max.

Controlled power supply

110...120Vac or 220...240Vac max. (Factory adjusted)

50-60 Hz

Power 1650VA max.

Max. Ambient temperature

50°C max.

2.10 Caution

Each system is pressure tested to at least 1.5 times the working pressure of the process conditions stipulated by the customer, with a minimum of 8 bar.

This test pressure is stated on the CEM valve with a Red Coloured sticker.

Check test pressure before installing in the line.

If this sticker is not available, or the test pressure is incorrect, the instrument should not be mounted in the process line and be returned to the factory.

Each instrument is leak tested to at least $2 \cdot 10^{-9}$ mbar.l/s Helium.

2.11 Supply pressure

Do not apply pressure until electrical connections are made. When applying pressure to the system, take care to avoid pressure shocks in the system, and increase pressure gradually. Be sure that all setpoints are at zero when doing so.

2.12 System purging

If corrosive or reactive fluids are used, purging with an inert gas is absolutely necessary, because if the tubing has been exposed to air, introducing these fluids will tend to clog up or corrode the system due to a chemical reaction with air or moist air.

Complete, long term purging is also required to remove such fluids from the system before exposing it to air. It is preferred not to expose the system to air, when working with these corrosive fluids. Cycled purging and evacuating is preferred.

2.13 Seals

Bronkhorst® has gathered a material compatibility chart from a number of sources believed to be reliable. However, it is a general guide only. Operating conditions may substantially change the accuracy of this guide. Therefore is no liability for damages accruing from the use of this guide. The customer's application demands its own specific design or test evaluation for optimum reliability. So check if the seals are correct for your process. However the CEM system has metal seals for all connections. Only the valve plunger is an elastomer.

3 Operation

3.1 General

The Bronkhorst® CEM system is designed in such a way that it will meet user process requirements. In order to achieve good results, it should be operated according to the guidelines stated in the following paragraphs.

3.2 Power and warm-up

Before switching on power, check if you have connected all devices according to the system description and/or hook-up diagram. Check the liquid and gas connections, and make sure there are no leakages, turn on power for at least 30 minutes to warm up flow controllers. For start-up of the liquid controller consult the appropriate manual. During this warming-up period the temperature of the heat exchanger might be brought up to its operating point.

3.3 Start-up/close-down

Be sure that the temperature of the heat exchanger is in accordance with the process conditions to be adjusted, and furthermore should all pressure levels have the correct values.

After this has been assured, first start bringing up the carrier gas flow to the correct level. Once this flow has been stabilised, the liquid flow can be applied to the system, by gradually increasing the setpoint of the liquid controller. Now your CEM system should be operating.

When closing down operation of the system proceed in reverse order.

First stop the liquid flow, and after that the gas flow.

Note:

Make sure there is always gas flow whenever liquid flow is present.

Operation example:

Application: Generation of humid gas

The CEM system can be used for generating certain humidity in a gas stream. The F-201 gas flow controller controls the gas flow and the LIQUI-FLOW® controller controls the humidity, the water.

The water is mixed with the gas and consequently evaporated. The humidity at a certain temperature corresponds with a certain ratio of gas and water, this ratio can be set by the flow controllers.

Example:

At atmospheric pressure, at 80°C, 2 l/min Air has to be moistened. Which water flow is needed for a r.h. of 50%. The vapor pressure of water at 80°C is 473.3 mbar according to Fluidat.

At 100% r.h., the (mole) ratio between gas and water is

MoleRatio:

$$X = \frac{473.3}{(1013.25 - 473.3)} = 0.877$$

So in a gas flow of 2 l/min, the saturated water flow (100% r.h.) is:

$$\Phi_{water} = X \cdot \Phi_{gas} = 0.877 \cdot 2 = 1.754 \text{ [l/min]}$$

and in [g/h]

$$\frac{1.754 \left[\frac{\text{l}}{\text{min}} \right] \cdot 18 \left[\frac{\text{g}}{\text{mol}} \right] \cdot 60 \left[\frac{\text{min}}{\text{h}} \right]}{22.4 \left[\frac{\text{l}}{\text{mol}} \right]} = 84.56 \text{ [g/h]}$$

By 50% r.h., the (mole) ratio between gas and water:

$$r.h.\% = \frac{e}{e_{sat}} \cdot 100 \quad e = \frac{50 \cdot 473.3}{100} = 236.6 \text{ [mbar]}$$

the moleRatio:

$$X = \frac{236.6}{(1013.25 - 236.6)} = 0.305$$

so in a gas flow of 2 l/min, the saturated water flow (50% r.h.) is:

$$\Phi_{water} = X \cdot \Phi_{gas} = 0.305 \cdot 2 = 0.61 \text{ [l/min]}$$

and in [g/h]

$$\frac{0.61 \left[\frac{\text{l}}{\text{min}} \right] \cdot 18 \left[\frac{\text{g}}{\text{mol}} \right] \cdot 60 \left[\frac{\text{min}}{\text{h}} \right]}{22.4 \left[\frac{\text{l}}{\text{mol}} \right]} = 29.41 \text{ [g/h]}$$

At 50% r.h., the waterflow is 29.41 g/h.

(*) Assumptions: Consider water vapour as an ideal gas, 1 mole of ideal gas at normal conditions = 22.4 l, 1 mole of water is 18 g and 1 hour is 60 min.
1 atm. = 1013.25 mbar.

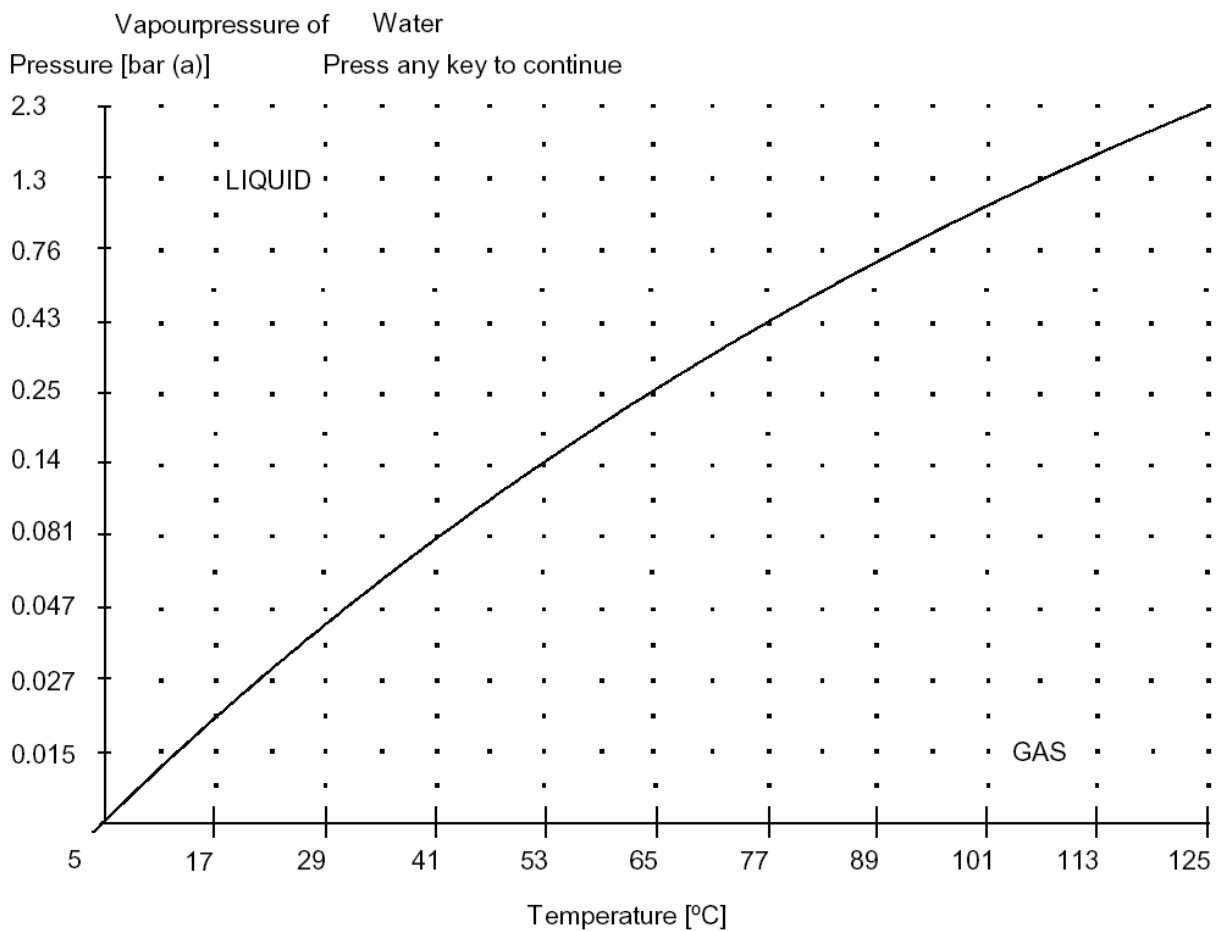

4 Readout and Control unit

The use of standard readout unit, manufactured by Bronkhorst® is recommended.

4.1 Application with Bronkhorst® standard Readout and Control unit

4.1.1 General

The Bronkhorst® Readout and Control unit with temperature control unit offers the ability to power the CEM and to set the desired temperature for the heater system of the CEM. The temperature inside the CEM is monitored with a PT-100 temperature sensor, the signal of which is being used by the temperature controller to control the adjusted temperature.

4.1.2 Rear panel connector

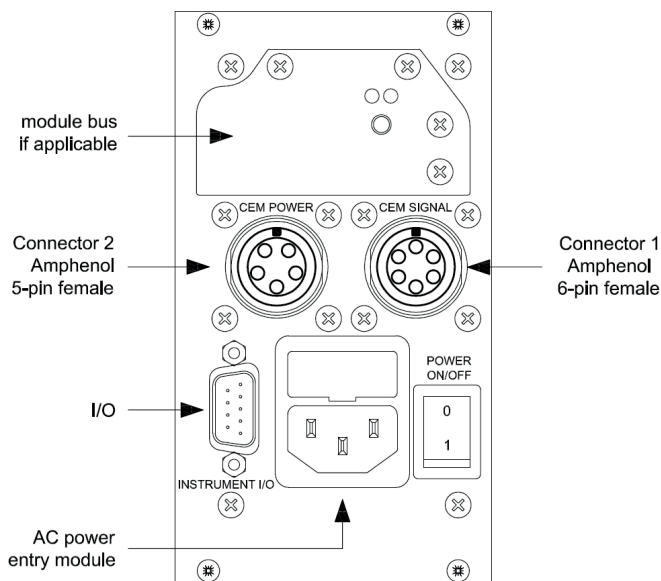

connector (1) 6-pin female

Pinnumber	Description
A	Not connected
B	Not connected
C	PT100 (T-sensor)
D	PT100 (T-sensor)
E	Safety switch
F	Safety switch

connector (2) 5-pin female

Pinnumber	Description	Description
	110...120Vac supply	220...240Vac supply
A	PE	PE
B	Heater (N)	Not connected
C	Heater (L)	Heater (N)
D	Heater (L)	Heater (L)
E	Heater (N)	Not connected

For other signals consult manual 9.17.076

4.1.3 Operation

For operation of the E-8000 based R/C panel consult manual 9.17.076.

4.2 Application with none Bronkhorst® Readout and Control unit

4.2.1 Recommended graphical diagram heater system

In the drawing below the recommended electrical diagram of a heater controlled system is shown.

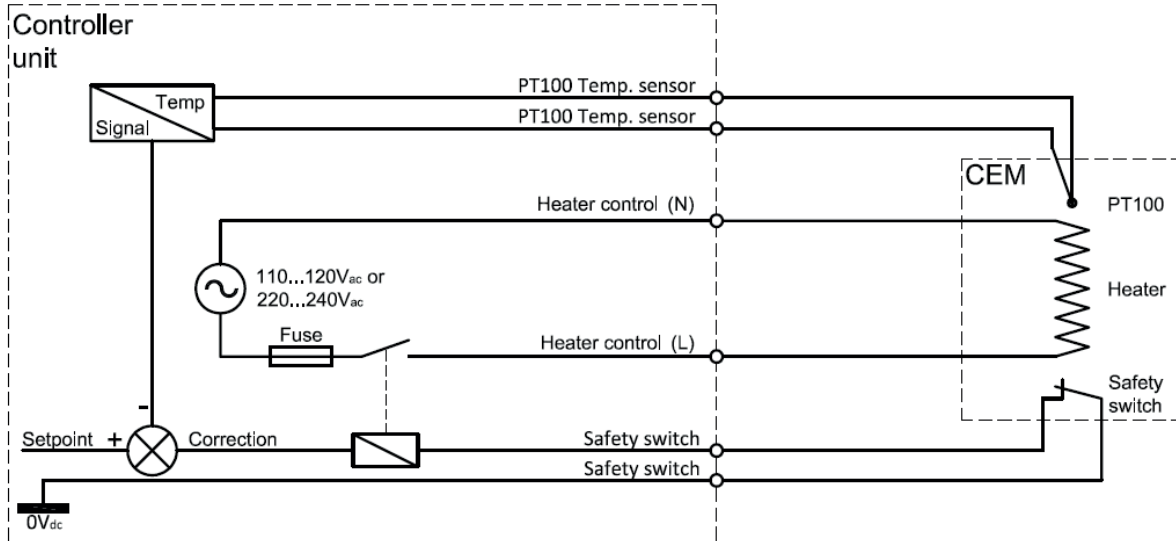

For proper connection, please consult the appropriate hook-up diagrams.

CAUTION !!

When using the CEM system without the Bronkhorst® Readout and Control unit the following guidelines should be followed:

- The heat exchanger does not contain a fuse. This should be connected externally.
- The heat exchanger is not suitable for constant ac power supply.
- The heat exchanger should be part of a temperature-controlled loop.
- The safety switch inside the heat exchanger is not part of the ac power supply circuit.

5 Cables

5.1 EMC and cables

All system set-ups described in this manual carry the CE-mark.
Therefore they have to comply with the EMC requirements as are valid for this kind of equipment.

However compliance with the EMC requirements is not possible without the use of proper cables and connector/packing gland assemblies.

Screens of cables should be carefully connected at both ends of the cable to the metal housing of the connector for good EMC behaviour.
For sensors and valves follow the guidelines as explained in the appropriate manuals.



*Warning: the "CEM power" connector is a mains power inlet.
Use standard Bronkhorst® cables 7.03.583 for connecting the CEM W-300B to the Readout unit or 7.03.584 for connecting the CEM W-300B to a non-Bronkhorst® control unit.
The  symbol on the CEM indicates the location of the power inlet*

APPENDIX 1

Recommendations for handling the Bronkhorst[®] DLI (CEM) system

**Vacuum system
Non Vacuum system**

Startup using Vacuum

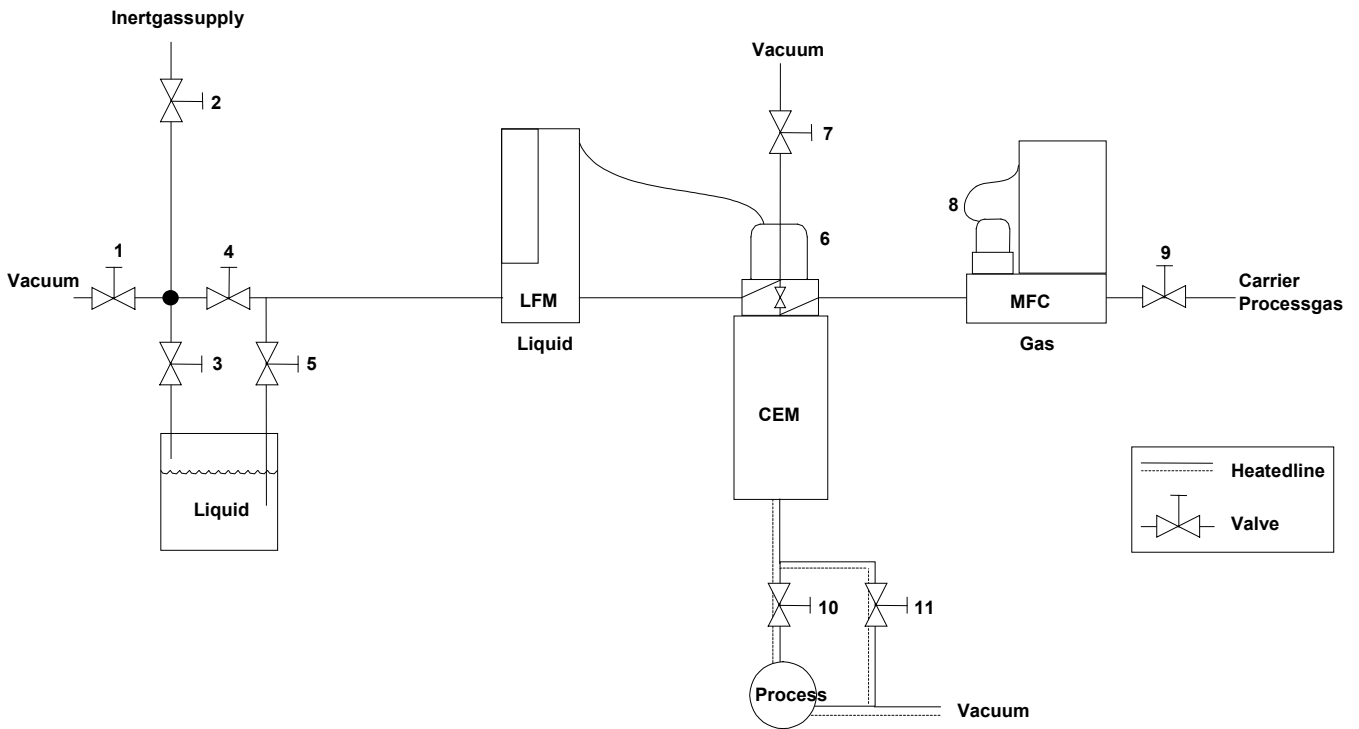

A) To fill the system:

Procedure:	Actions:
A1) Evacuate the lines "Vacuum"	Start pumps
A2) Evacuate all lines	Close: 2,3,5,10 and 9. Connect inert gas on carrier gas inlet. Open : 1,4,7,11. Give setpoint to gas and liquid control (the control valves 6 and 8 open). Pump for a long time. Remark: if the system is not completely dry follow procedure of E3, E4, (E5).
A3) Purge line between inert gas source and valve 2.	Close: 4. Open valve 2 briefly for some seconds.
A4) Purge line between process gas source and gas MFC.	Give setpoint = 0 to LFM (6 closes). Open valve 9 briefly for some seconds.
A5) Pump down liquid supply.	Open 3 for some time, close 3.
A6) Pressurize liquid supply.	Close 1, give right pressure on inert gas supply. Open 2, open 3 briefly.
A7) Fill the system with liquid. ⁽¹⁾	Let gas flow in the carrier gas line during filling of the system. Close 7. Open 5 briefly, allow mixing valve 6 to fill.
A8) Optional: degassing mixing valve.	Open 7, a needle valve will be best, to avoid too much liquid be pumped away.
A9) The system is now ready for use.	

B) To start the process:

Procedure:	Actions:
B1) Set the CEM heater at right temperature.	Give setpoint to the heater, wait until temperature is reached.
B2) Start gas flow. ⁽¹⁾	Open 9. Give setpoint to gas MFC.
B3) Start liquid flow. ⁽²⁾	Give setpoint to liquid flow controller, wait until stabilization.
B4) Connect process.	Open 10, close 11.

C) To stop the process:

Procedure:	Actions:
C1) Disconnect process.	Open 11, close 10.
C2) Stop liquid flow.	Give setpoint = 0 to liquid flow controller.
C3) Optional: Stop gas flow. ⁽¹⁾	Give setpoint = 0 to gas MFC.

D) How to leave system overnight:

Procedure:	Actions:
D1) Relieve the supply pressure from the liquid supply and lines.	Close 2, close 5 and open 1 for some seconds. Relief pressure inert gas supply, open 2.
D2) Leave system unused.	Close 3. Preferably, keep pumping the lines, close 2, open 1.
D3) Before startup, pressurize liquid supply.	Close 1 and open 2. Open 3 and 5.
D4) System is now ready for use.	Proceed according to B.

E) To empty and purge the system: ^(3,4)

Procedure:	Actions:
E1) Follow procedure "How to leave system overnight" until "leave system unused".	See D1 and D2.
E2) Purge liquid out of lines.	Open 4 and 7.
E3) Purge lines with inert gas.	Close 1. Open 2 briefly for some time.
E4) Evacuate liquid lines (cont.).	Close 2, open 1.
E5) Optional: Repeat last two steps for a few times.	

¹ Make sure that the carrier gas is always flowing when the liquid flow is on. Preferably, let always gas flow in the carrier gas line when the system is filled with liquid.

² Close supply pressure of the liquid vessel during the process. The pressure controller of the inert gas supply can influence the stability of the liquid flow controller.

³ If the liquid is reactive or aggressive, be sure to remove air (and water vapor) carefully, before introducing liquid in the system.

⁴ If the liquid is reactive, aggressive, poisonous, toxic, or flammable, beware that the system is purged fully (preferably with inert liquid, E3, E4, E5) before opening the system.

Remarks:

- In case of non-pure liquids, place a filter just before the Liqui-Flow.
- Mount the CEM system vertical.

Startup without using Vacuum

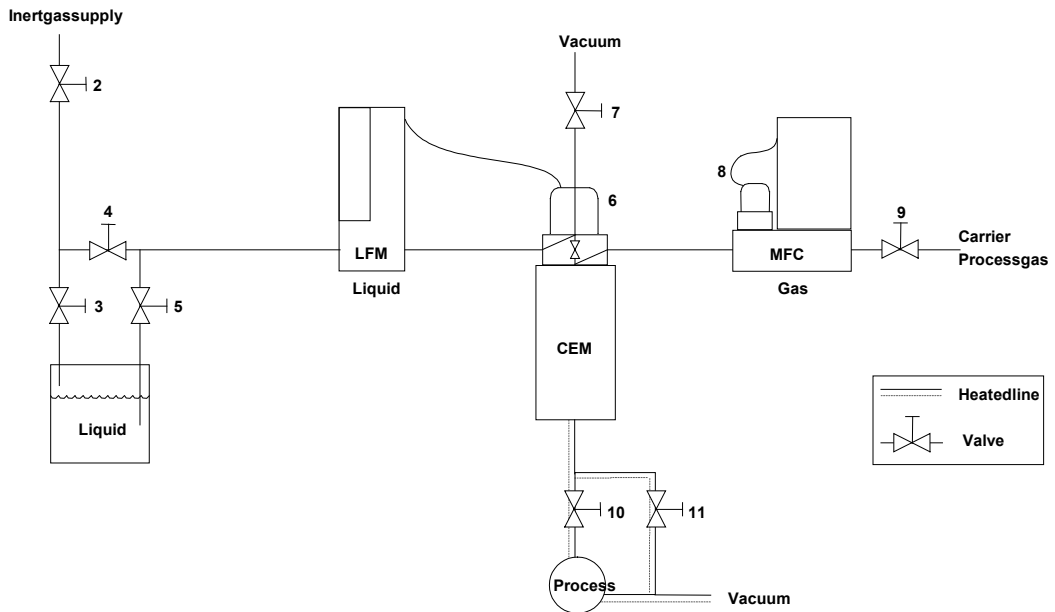

A) To fill the system:

Procedure:	Actions:
A1) Purge all lines	Close: 3, 5 and 10. Connect inert gas on carrier gas inlet. Open : 2, 4, 7, 9 and 11. Give setpoint to gas controller, the control valve 8 opens. Give setpoint = 0 to liquid - flow controller Purge for a long time.
A2) Pressurize liquid supply.	Close 4, give right pressure on inert gas supply. Open 3.
A3) Fill the system with liquid. ⁽¹⁾	Let gas flow in the carrier gas line during filling of the system. Open 5 briefly, allow mixing valve 6 to fill. Wait until all gas bubbles left the system, then close 7.
A4) The system is now ready for use.	

¹ Make sure that the carrier gas is always flowing when the liquid flow is on. Preferably, let always gas flow in the carrier gas line when the system is filled with liquid.

B) To start the process:

Procedure:	Actions:
B1) Set the CEM heater at right temperature.	Give setpoint to the heater, wait until the temperature is stabilized.
B2) Start gas flow. ⁽¹⁾	Give setpoint to gas MFC.
B3) Start liquid flow. ⁽²⁾	Give setpoint to liquid flow controller, wait until stabilization.
B4) Connect process.	Open 10, close 11.

C) To stop the process:

Procedure:	Actions:
C1) Disconnect process.	Open 11, close 10.
C2) Stop liquid flow.	Give setpoint = 0 to liquid flow controller.
C3) Optional: Stop gas flow. ⁽¹⁾	Give setpoint = 0 to gas MFC.

D) How to leave system overnight:

Procedure:	Actions:
D1) Relieve the supply pressure from the liquid supply and lines.	Close 5. Relief pressure inert gas supply. Open 2.
D2) Leave system unused.	Close 3. Close 2.
D3) Before startup, pressurize liquid supply.	Open 2. Open 3 and 5.
D4) System is now ready for use.	Proceed according to B.

E) To empty and purge the system.^(3,4)

Procedure:	Actions:
E1) Follow procedure "How to leave system overnight" until "leave system unused".	See D1 and D2.
E2) Purge liquid out of lines.	Open 4 and 7, open 2
E3) Purge lines with inert gas.	Purge for long time.
E4) Optional: Purge with inert liquid.	Connect inert liquid to inert gas supply . Proceed according to E2.
E5) Optional: Alter E3 and E4 for a few times.	

¹ Make sure that the carrier gas is always flowing when the liquid flow is on. Preferably, let always gas flow in the carrier gas line when the system is filled with liquid.

² Close supply pressure of the liquid vessel during the process. The pressure controller of the inert gas supply can influence the stability of the liquid flow controller.

³ If the liquid is reactive or aggressive, be sure to remove air (and water vapor) carefully, before introducing liquid in the system.

⁴ If the liquid is reactive, aggressive, poisonous, toxic, or flammable, beware that the system is purged fully (preferably with inert liquid, E3, E4, E5) before opening the system.

Remarks:

- In case of non-pure liquids, place a filter just before the Liqui-Flow.
- Mount the CEM system vertical.

APPENDIX 2

Enclosures (if applicable)

Declaration on contamination
Dimensional drawings
Hook-up diagram